

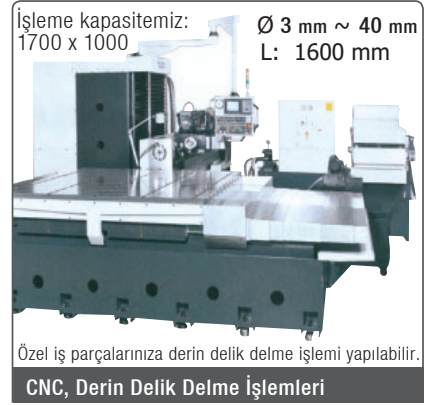

Standart, Enjeksiyon Kalıp Setleri



Özel İmalat, Enjeksiyon Kalıp Setleri



Standart / Hazır - Enj. Kalıp Set, Seçim Kombinasyonu

Üretim: **GTH**

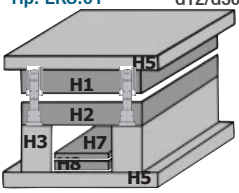
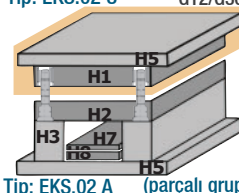
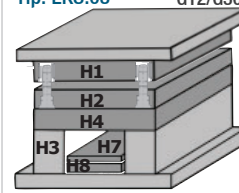
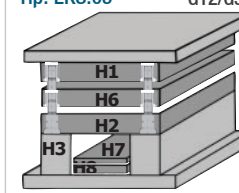
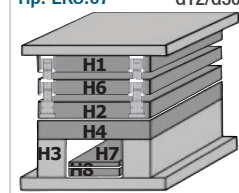
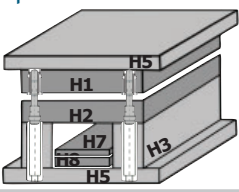
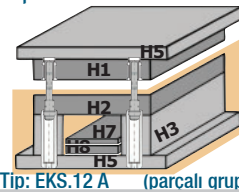
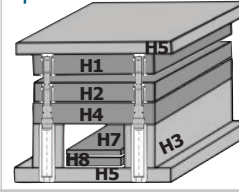
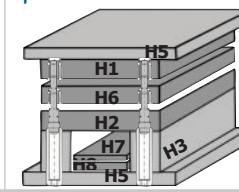
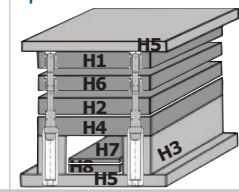
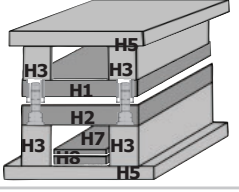
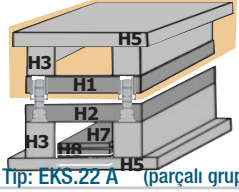
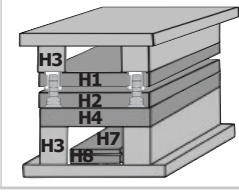
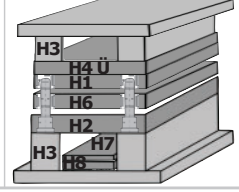
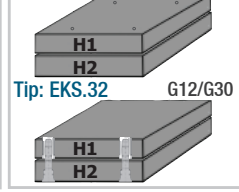
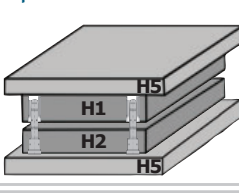
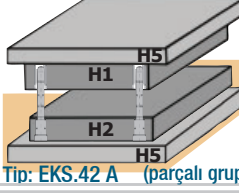
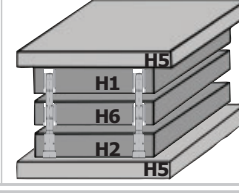
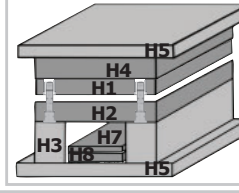
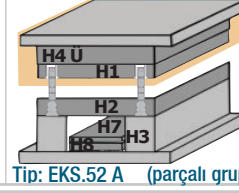
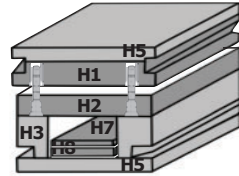
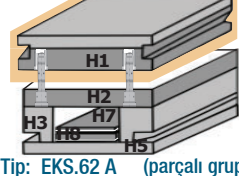
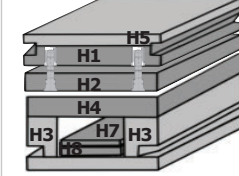
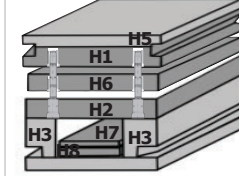
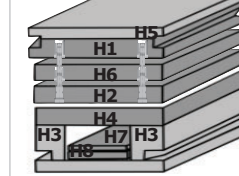
<p>Tip: EKS.01 G12/G30</p> 	<p>Tip: EKS.02 U G12/G30</p>  <p>Tip: EKS.02 A (parçalı grup)</p>	<p>Tip: EKS.03 G12/G30</p> 	<p>Tip: EKS.05 G12/G30</p> 	<p>Tip: EKS.07 G12/G30</p> 
<p>Tip: EKS.11 G13/G31/G28</p> 	<p>Tip: EKS.12 U G13/G31/G28</p>  <p>Tip: EKS.12 A (parçalı grup)</p>	<p>Tip: EKS.13 G13/G31/G28</p> 	<p>Tip: EKS.15 G13/G31/G28</p> 	<p>Tip: EKS.17 G13/G31/G28</p> 
<p>Tip: EKS.21 G12/G30</p> 	<p>Tip: EKS.22 U G12/G30</p>  <p>Tip: EKS.22 A (parçalı grup)</p>	<p>Tip: EKS.23 G12/G30</p> 	<p>Tip: EKS.25 G12/G30</p> 	<p>Tip: EKS.30</p>  <p>Tip: EKS.32 G12/G30</p>
<p>Tip: EKS.41 G12/G30</p> 	<p>Tip: EKS.42 U G12/G30</p>  <p>Tip: EKS.42 A (parçalı grup)</p>	<p>Tip: EKS.43 G12/G30</p> 	<p>Tip: EKS.51 G12/G30</p> 	<p>Tip: EKS.52 U G12/G30</p>  <p>Tip: EKS.52 A (parçalı grup)</p>
<p>Tip: EKS.61 G12/G30</p> 	<p>Tip: EKS.62 U G12/G30</p>  <p>Tip: EKS.62 A (parçalı grup)</p>	<p>Tip: EKS.63 G12/G30</p> 	<p>Tip: EKS.65 G12/G30</p> 	<p>Tip: EKS.67 G12/G30</p> 



"Tecrübe, uzmanlık ve GTH kalitesine daima güvenebilirsiniz"

- Standart veya özel imalat kalıp setleriniz için isteğinize uygun CNC işlemler yapılabilir.
- EKS.01 ~ EKS.07: Plastik enjeksiyon, standart set (kolon / burç donanımlı ve civata bağlantılı).
- EKS.11 ~ EKS.17: Plastik enjeksiyon, standart set (G13 / G31 / G28 donanımlı ve civata bağlantılı).
- EKS.21 ~ EKS.25: Plastik enjeksiyon, standart set (sıcak yolluk & manifold plaka yerleri oluşturulmuş ve civata bağlantılı).
- EKS.30 ~ EKS.32: Enjeksiyon kalıpları, standart set (hamil plaka grubu H1 - H2, isteğe göre bağlama kanallı yapılabilir).
- EKS.41 ~ EKS.43: Plastik enjeksiyon, standart set (düz hamil plakalı set, itici plakalar ve takozlar hariç konumlanmış tip).
- EKS.51 ~ EKS.52: Plastik enjeksiyon, standart set (dişi hamil plakasına H4 destek plakası ilave edilmiş tip).
- EKS.61 ~ EKS.67: Metal enjeksiyon, standart set (bağlantı sistemi, bağlama kapağı ile dişi hamilde oluşturulmuş tip).

Standart, Enjeksiyon Kalıp Setleri Seçim Tablosu

Kod: EKS

Güvenal
Kalıp Elemanları A.Ş.

Dış Ölçüler		Plaka Kalınlık Ölçü Seçimleri / mm								Plaka Eksenleri / mm						Kolon Burç	Cıvata							
A	L	H5	H1	H2	H6	H4	H7	H8	H3	A1	A2	A3	A4	L1	L2	M	m							
156	156	27 37		27-37 47-57 67	17	17	47 57 67	196	114	80	56	114	60	16	M8 M10									
	196											154	100											
	246											204	150											
	296											254	200											
	346											304	250											
196	196	27 37		27-37 47-57 67-77	17	17	47 57 67	246	154	120	96	154	100	16	M8 M10									
	246											204	150											
	296											254	200											
	346											304	250											
	396											354	300											
246	246	27 37		27-37 47-57 67-77	17	17	47 57 67 77 87 97	296	194	148	126	194	130	20 25	M8 M12									
	296											244	180											
	346											294	230											
	396											344	280											
	446											394	330											
296	296	27 37		27-37 47-57 77-67 87	17	17	57 67 77 87 97	346	244	198	176	244	180	25	M8 M12									
	346											294	230											
	396											344	280											
	446											394	330											
	496											444	380											
346	346	27 37		37-47 57-67 77-87 97	17	22	57 67 77 87 97	396	294	228	202	294	220	25	M10 M12 M16									
	396											344	270											
	446											394	320											
	496											444	370											
	546											494	420											
396	396	27 37		37-47 57-67 77-87 97	17	22	57 67 77 87 97	446	324	278	252	324	230	30	M10 M16									
	446											374	280											
	496											424	330											
	546											474	380											
	596											524	430											
446	446	27 37 47		37-47 57-67 77-87 97	17	22	57 67 77 87 97	496	374	328	302	374	280	30	M10 M16									
	496											424	330											
	546											474	380											
	596											524	430											
	646											574	480											
496	496	37 47 57		37-47 57-67 77-87 97	17	22	57 67 77 87 97	546	424	378	348	424	330	30	M10 M16									
	546											474	380											
	596											524	430											
	646											574	480											
	696											624	530											
546	546	596	646	696	746	796	846	896	946	796	846	896	946	796	846	896	946							
	596																	646	696	746	796	846	896	946
	646																	696	746	796	846	896	946	946
	696																	746	796	846	896	946	946	946

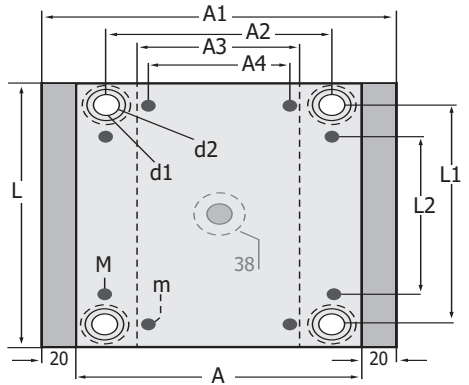
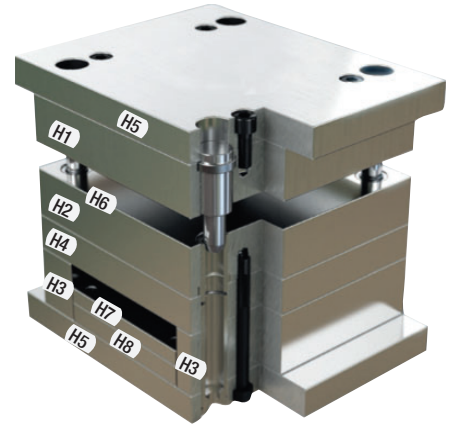
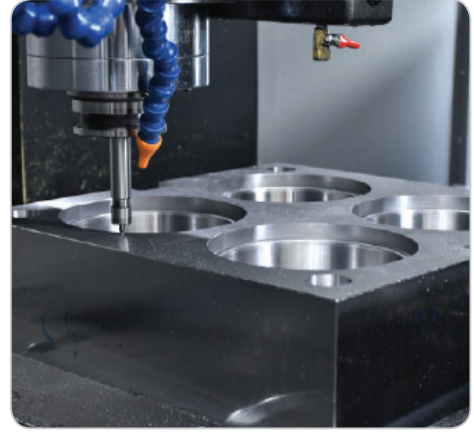

Standart, Enjeksiyon Kalıp Setleri:

Standart Kalıplar; yandaki tablomuzu izleyerek ölçüler dahilinde oluşturulabilir. **İsteğe göre özel setleriniz plakalarınız** çalışma datalarınızın seyrinde işlenecektir. Ayrıca isteğe göre; Kalıp kitlenme yeri, baskı sayaçların yerleri, o-ring yerleri, soğutma kanalları (CNC derin delik delmede) sıcak yolluk sistemlerin oluşumu, manifold plaka işlemleri, itici pim ve istenen delik yuvaları, lokmalı kalıp (flanş yuvaları işlemi) açılı veya düz maça yerleri dahilinde, istenilen havuz yerleri hassas ve karşılıklı kontrollü bir akış ile işlenir. İsteğe göre kolon burç bağlantılı veya açık plakalar halinde işinizin hızına göre seviyatlandırılır, bu şekilde kalıp üretimimize eklenecek set üretimi konusundaki tecrübe / uzmanlık ve çalışma metodlarımızla kalıp projelerinize hızlı - hassas ve ekonomik şekilde destek oluyoruz.

Sipariş: EKS.. A x L
H1-H2-H4/H6/H3

Malzeme: CK45 veya
isteğinize uygun malzeme